

5 & 8-Channel CWDM Passive Filter ISP (Indoor Use)

Product Description:

5 or 8-Channel ISP CWDM Filter with the following options:

- Express/Test Ports
- 1310/1550 Wideband Parts
- Single/Dual/Twin LGX Form Factor
- UPC/APC Connectors
- Industrial Temperature Hardened



Product Ordering Information

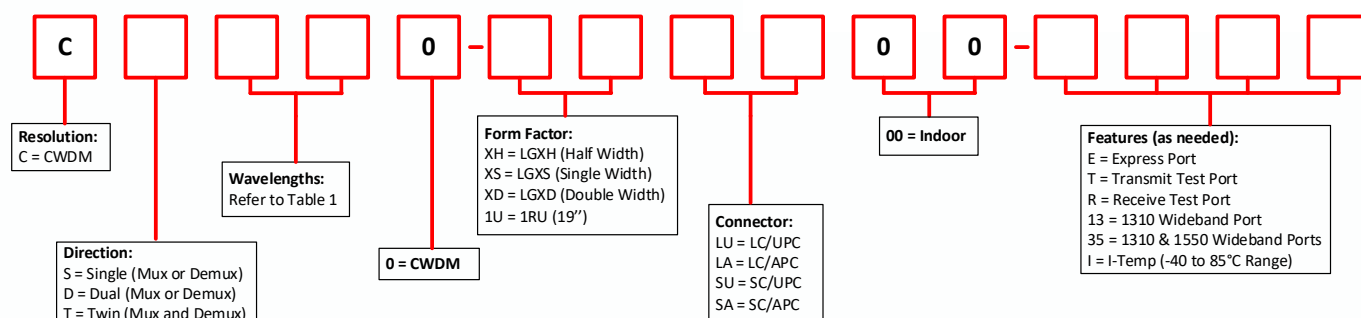

Table 1

CHANNEL DESIGNATION
8A = ITU 1431 - 1611 (skipping 1551 & 1571)
8B = ITU 1471 - 1611
8C = ITU 1431 - 1611 (skipping 1531 & 1551)
5B = ITU 1471 - 1511, 1591 - 1611

Part Number / Description Examples

Part Number	Single Description
CS8A0-XSLU00-ETR	CWDM, Single (Mux or Demux), 1431-1611nm, without 1551 & 1571nm, LGX single width, LC-UPC, with Express + Transmit Test + Receive Test ports, Thin Film Filter
CS8B0-XSLA00-ETR	CWDM, Single (Mux or Demux), 1471-1611nm, LGX single width, LC-APC, with Express + Transmit Test + Receive Test ports, Thin Film Filter
Part Number	Dual Description
CD8A0-XSLA00-ETR	CWDM, Dual (Mux or Demux), 1431-1611nm, without 1551 & 1571nm, LGX single width, LC-APC, with Express + Transmit Test + Receive Test ports, Thin Film Filter
CD8B0-XSLU00-ETR	CWDM, Dual (Mux or Demux), 1471-1611nm, LGX single width, LC-UPC, with Express + Transmit Test + Receive Test ports, Thin Film Filter

Part Number	Twin Description
CT8A0-XSLU00-ETR	CWDM, Twin (Mux + Demux), 1431-1611nm, without 1551 & 1571nm, LGX single width, LC-UPC, with Express + Transmit Test + Receive Test ports, Thin Film Filter
CT8B0-XSLA00-ETR	CWDM, Twin (Mux + Demux), 1471-1611nm, LGX single width, LC-APC, with Express + Transmit Test + Receive Test ports, Thin Film Filter
CT8C0-XSLU00-ETR13	CWDM, Twin (Mux + Demux), 1431-1611nm, without 1531 & 1551nm, LGX single width, LC-UPC, with Express + Transmit Test + Receive Test + 1310nm wideband port, Thin Film Filter
CT5B0-XSLU00-E35	CWDM, Twin (Mux + Demux), 1471, 1491, 1511, 1591, 1610nm, LGX single width, LC-UPC, with Express + 1310nm wideband + 1550nm wideband ports, Thin Film Filter

Optical Characteristics (8-channel)

Parameter	Value	Unit
CWDM Channels	1471, 1491, 1511, 1531, 1551, 1571, 1591, 1611	nm
CWDM Passband @ -0.5dB	$\lambda_c \pm 6.5$	nm
CWDM Passband insertion loss @ -0.5dB	< 3.0	dB
CWDM Passband ripple @ -0.5dB	≤ 0.5	dB
Test port insertion loss	20 ± 2	dB
Express insertion loss	< 3.0	dB
Express passband ripple	≤ 0.5	dB
Express passband – Type B	1260-1460 (1420-1460 w/ 1310 Port) 1620-1635	nm
Express passband – Type A	1260-1420 (negligible w/ 1310 Port) 1540-1580, 1620-1635	nm
1310 port insertion loss	< 2.8	dB
1310 port passband ripple	< 0.5	dB
1310 port passband	$\sim 1260-1360$	dB
CWDM uniformity	≤ 2.0	dB
Isolation Adj (COM-CWDM)	> 35	dB
Isolation Non-Adj (COM-CWDM)	> 45	dB
Isolation (COM-EXP)	> 15	dB
CWDM directivity	≥ 50	dB
EXPRESS directivity	≥ 65	dB
Return loss	> 45	dB
Polarization dependent loss	< 0.2	dB
Polarization mode dispersion	≤ 0.1	ps
IL thermal stability	≤ 0.006	dB/°C
Wavelength thermal stability	≤ 0.002	nm/°C
Maximum input power	300 / 24.8	mW/dBm
Operating temperature	-10 to +70	°C
Operating humidity	5 to 95	%RH
Tensile strength pull strength (up to 10 seconds max)	> 20 ³	N
Fiber type (all ports)	SMF-28e (G.657.A1)	

Optical Characteristics (5-channel)

Parameter	Value	Unit
CWDM channels	1471, 1491, 1511, 1591, 1611	nm
CWDM Passband @ -0.5dB	$\lambda_c \pm 6.5$	nm
CWDM passband insertion loss @ -0.5dB	< 2.2	dB
CWDM Passband ripple @ -0.5dB	≤ 0.5	dB
Test port insertion loss	20 ± 2	dB
Express insertion loss	< 2.5	dB
Express passband ripple	≤ 0.5	dB
Express passband	1260-1460 (1420-1460 w/ 1310 Port) 1620-1635	nm
1310 port insertion loss	< 2.8	dB
1310 port passband ripple	≤ 0.5	dB
1310 port passband	~1260-1360	nm
1550 port insertion loss	< 2.5	dB
1550 port passband ripple	≤ 0.5	dB
1550 port passband	~1527-1567	nm
CWDM uniformity	≤ 1.5	dB
Isolation Adj – COM-CWDM	> 35	dB
Isolation Non-Adj – COM-CWDM	> 45	dB
Isolation Non-Adj – COM-EXP	> 15	dB
CWDM directivity	≥ 50	dB
EXPRESS directivity	≥ 65	dB
Return loss	> 45	dB
Polarization dependent loss	< 0.2	dB
Polarization mode dispersion	≤ 0.1	ps
IL thermal stability	≤ 0.006	dB/°C
Wavelength thermal stability	≤ 0.002	nm/°C
Maximum input power	300/24.8	mW/dBm
Operating temperature	-10 to +70	°C
Operating humidity	5 to 95	%RH
Fiber type (all ports)	SMF-28e (G.657.A1)	

Filter Optical Design

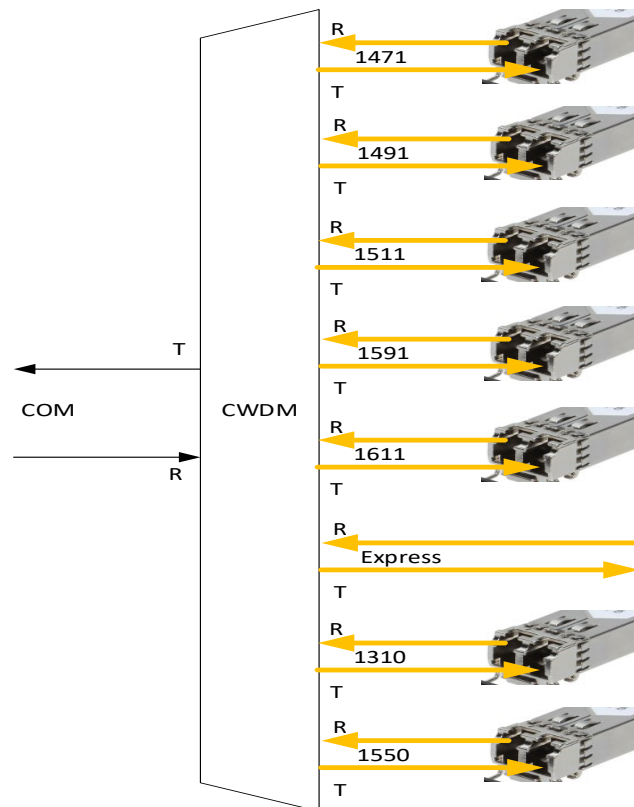
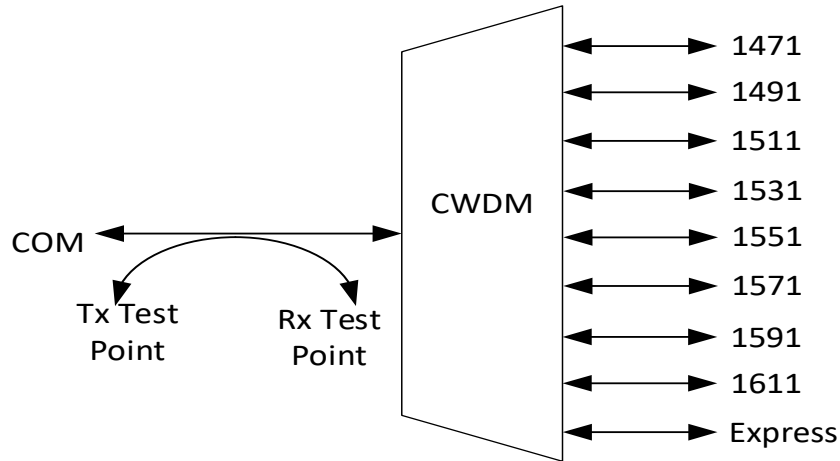

8-Channel Type B CWDM Design (both directions for Twin design)

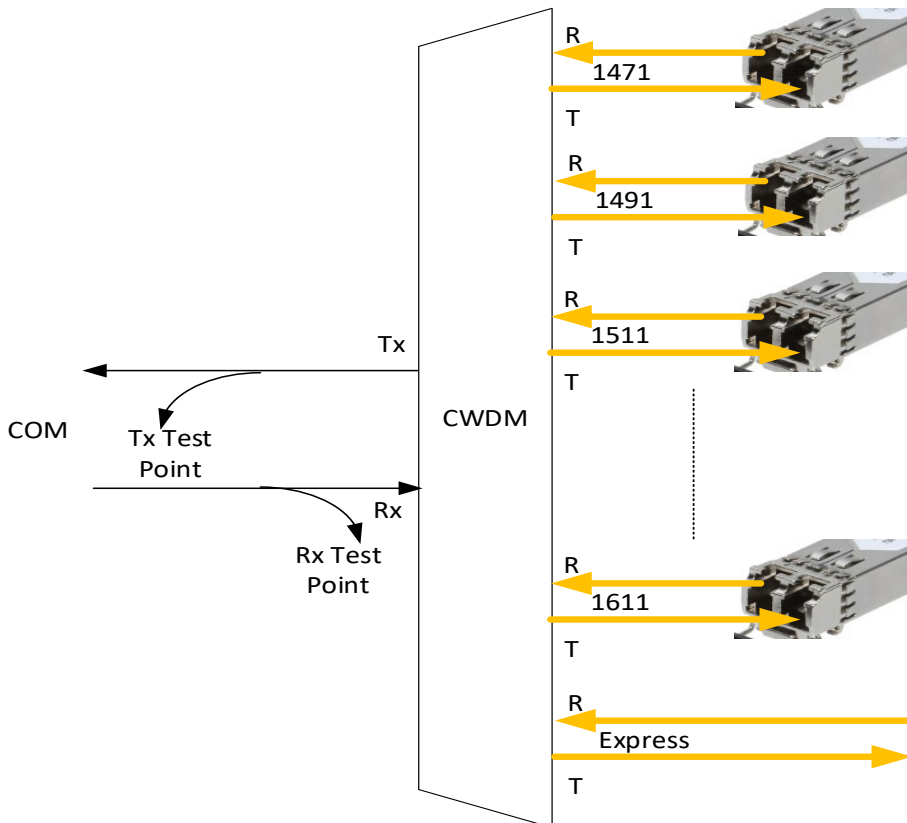
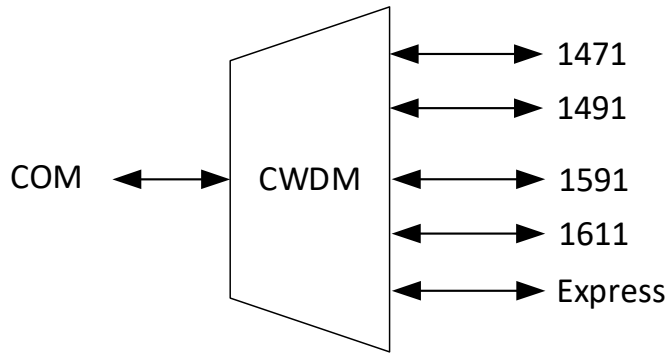

5-Channel CWDM Design (both directions for Twin design)

Filter Physical Design

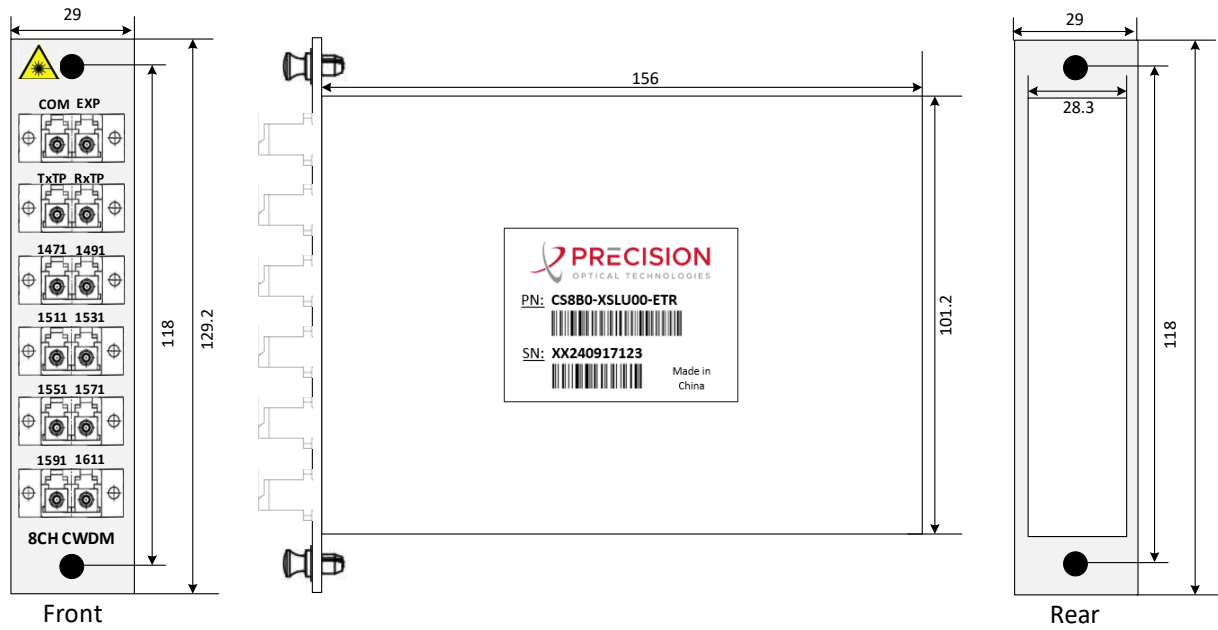

8-Channel Single CWDM External Design (mm)
(CS8B0-XSLU00-ETR shown)

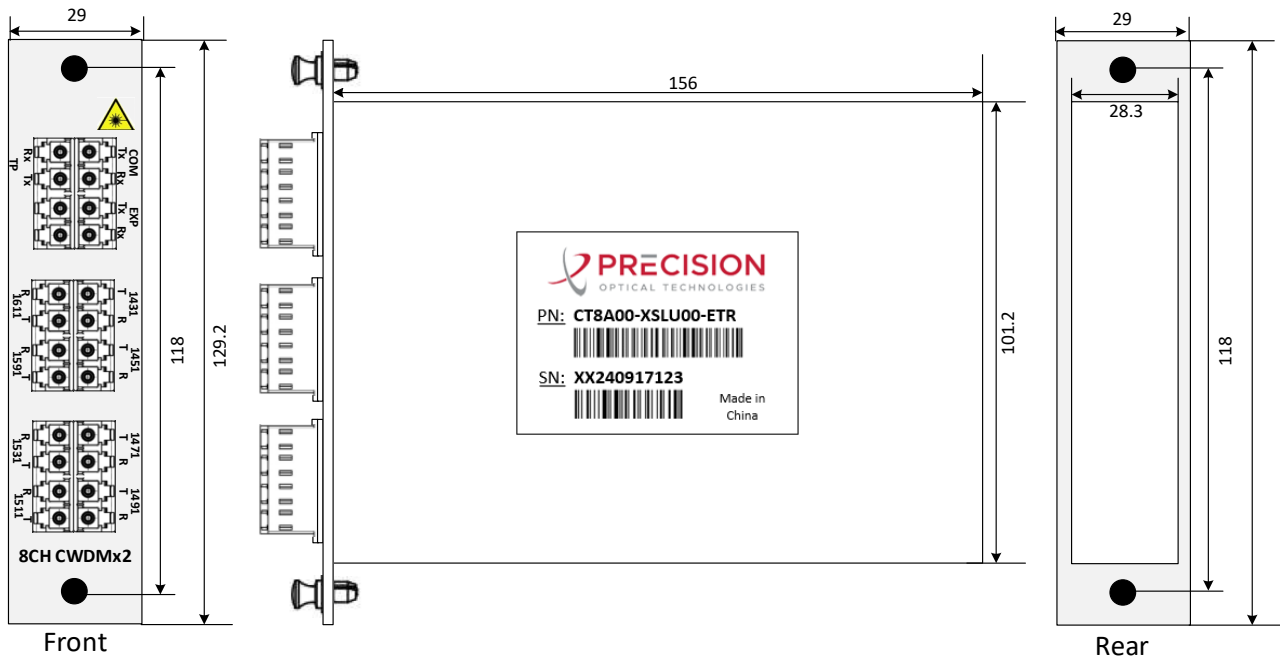

8-Channel Twin CWDM External Design (mm)
(CT8A0-XSLU00-ETR shown)

**5 & 8-Channel CWDM Passive Filter
ISP (Indoor Use)**

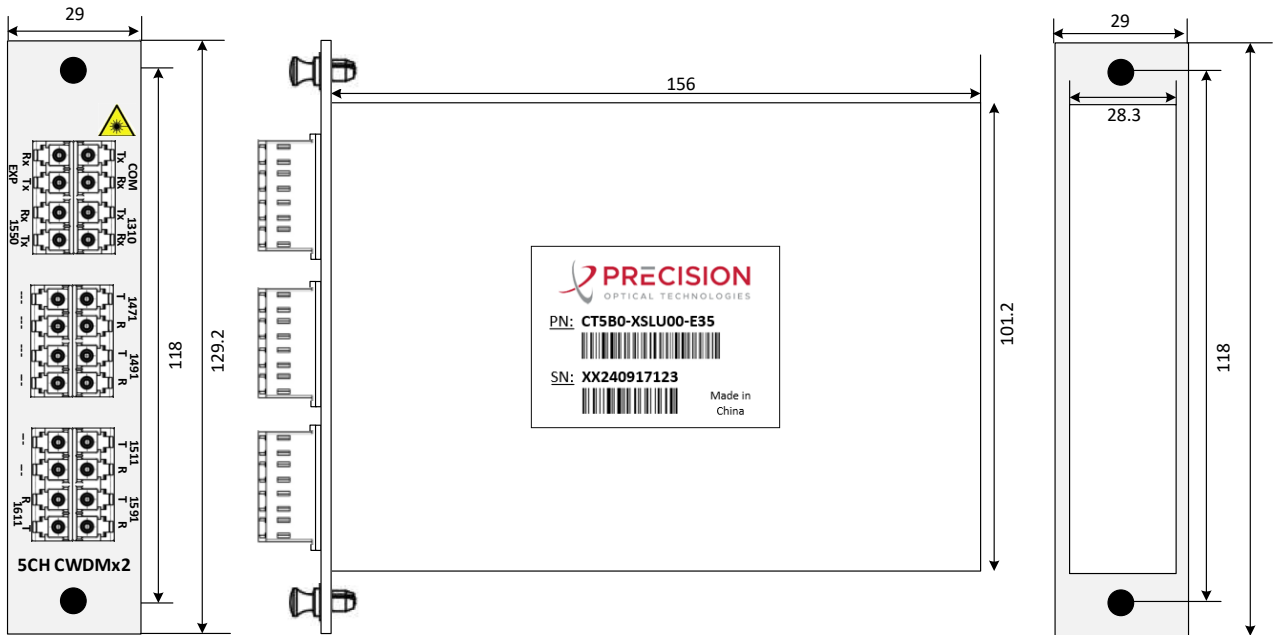

5-Channel Twin CWDM External Design (mm)
(CT5B0-XSLU00-E35 shown)